

NOTE:
THIS STEP IS A CRITICAL STEP THAT MUST BE DONE PRIOR TO THE FOLLOWING STEPS - OMITTING THIS STEP VOIDS THE WARRANTY

STEP 1 PRIORITY

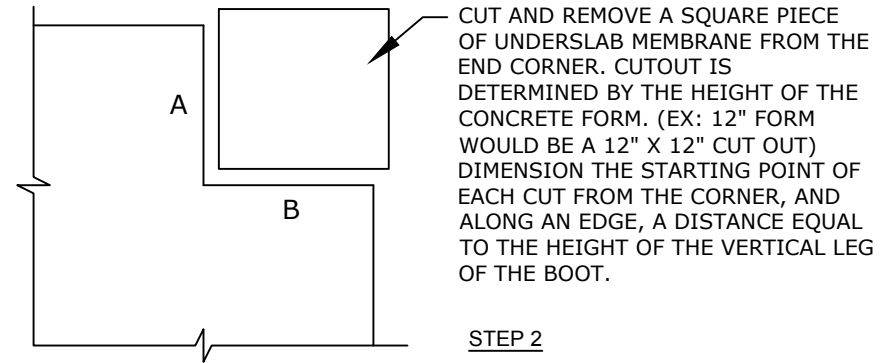

STEP 2

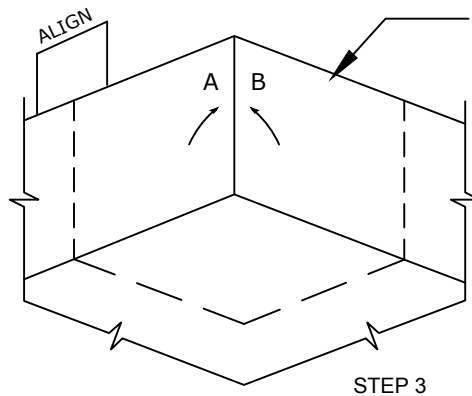

POSITION THE CUT UNDERSLAB MEMBRANE INTO THE CORNER AND OVER THE BOOT SO THE A AND B EDGES MEET IN THE VERTICAL LEG OF THE BOOT. FORM-FIT THE PIECE TO THE CONTOURS OF THE CORNER. CREASE THE UNDERSLAB MATERIAL TO ESTABLISH A CONFORMING SHAPE. AFTER CREASING, FOLD THE PIECE BACK, REMOVE THE RELEASE PAPER FROM THE HORIZONTAL LEG OF THE BOOT, THEN OVERLAY AND PRESS THE HORIZONTAL LEG INTO THE BOOT. REPEAT FOR EACH VERTICAL LEG.

STEP 3

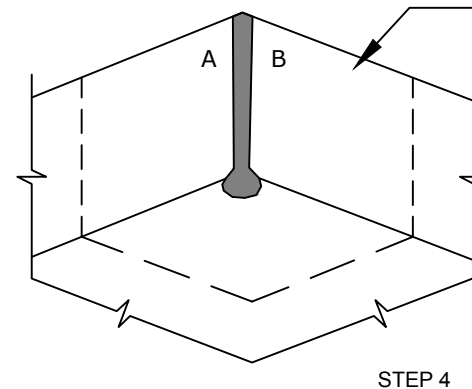

STEP 4

US11 SECTION@ US INSIDE CORNER DETAIL

© POLYGUARD PRODUCTS, INC.